

Product description

The optical receivers are intended to convert optical signals into electrical RF signals.

The receivers are dedicated to operate with suitable TERRA wideband SAT IF transmitting system. See manuals of appropriate devices in www.terraelectronics.com.

The products are intended for indoor usage only.

Safety instructions

Installation of the receiver must be done according IEC60728-11 and national safety standards.

The receiver is powered from low DC voltage, which is not dangerous to life.

Any repairs must be done by a skilled personnel.

To ensure safe operation of the receiver follow these instructions:

Do not connect supply voltage until all cables have been connected correctly.

The receiver shall not be exposed to dripping or splashing water.

Avoid placing the receiver next to central heating components and in areas of high humidity.

If the receiver has been kept in cold conditions for a long time, keep it in a warm room no less than 2 hours before powering.

The ventilation should not be impeded by covering receiver with items, such as newspapers, table-cloths, curtains.

Avoid looking directly into beam, laser light can cause eye injuries and result in permanent loss of vision.



This product complies with the relevant clauses of the European Directive 2002/96/EC. The unit must be recycled or discarded according to applicable local and national regulations.



Equipment intended for indoor usage only.



Functional grounding. Connect to the main potential equalization.



This product is in accordance to following norms of EU: EMC norm EN50083-2, safety norm EN IEC62368-1 and RoHS norm EN50581.



This product is in accordance with Custom Union Technical Regulations: "Electromagnetic compatibility of technical equipment" CU TR 020/2011, "On safety of low-voltage equipment" CU TR 004/2011.



This product is in accordance with safety standard AS/NZS 60065: 2012 and EMC standards of Australia.

Manual in .pdf



External view of the receiver

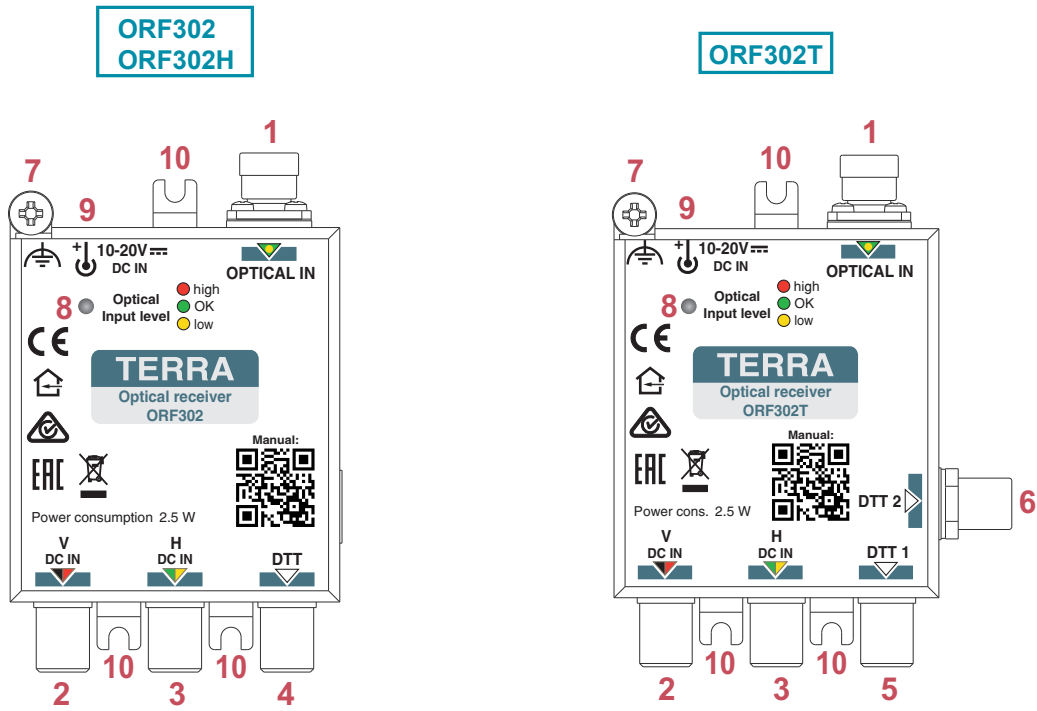

1. **OPTICAL IN** - optical input. FC type connector.
2. **V, DC IN** - SAT IF vertical polarization output, DC input. F socket.
3. **H, DC IN** - SAT IF horizontal polarization output, DC input. F socket.
4. **DTT** - DTT, DAB, FM output. F socket.
5. **DTT1** - DTT, DAB, FM output. F socket.
6. **DTT2** - DTT, DAB, FM output. F socket.
7. Functional grounding clamp
8. LED indicator of optical input power:
 - red – to high
 - green – correct (OLC range)
 - yellow – to low
9. **DC IN** - 10 V ÷ 20 V DC powering input (3.5/1.3 mm DC jack)
- 10 - mounting supports.

Figure 1. External view of the receivers

Optical connections

Note: All optical connectors and adaptors should be cleaned before connecting them.

If optical reception power of the receiver decrease, fiber connection should be cleaned and maintained. Fiber connectors should never be left uncovered.

1. Align the FC type connector key-way (type R) with the receptable key-way.

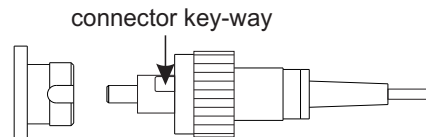

2. Push firmly to locate the key-ways and then rotate the coupling ring.

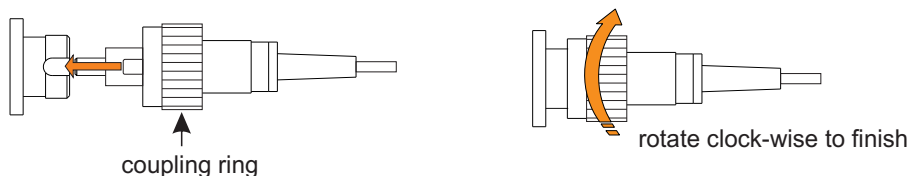

3. Do not exceed the minimum bending radius of fibers: must be not less 30 mm when connecting optic cable to the system.

Installation instructions

Read the safety instruction first.

All unused F type connectors must be terminated with 75 Ω loads.

Mount the receiver in vertical position with optical connector on top.

From top, left and right side leave 10 cm free space.

The receiver must be fixed with steel screws Ø 4-5 mm. Screws are not included in a package.

Powering

The receiver can be powered in two ways: from AC/DC adapter through 3.5/1.3 DC connector (pos. 9, Figure 1) or through RF outputs (pos. 2, 3 Figure 1).

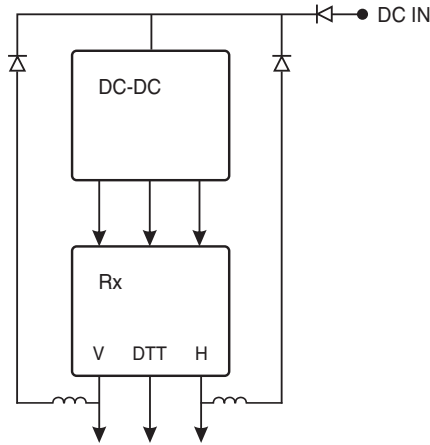



Figure 2. DC path diagram

Optical input and RF outputs

The operational optical input level of the receiver is -15...-5 dBm. In this region OLC is working and provides fixed RF output levels. Ensure optical input level in this range.

A direct optical connection cannot be made between the transmitter and the receiver. Use appropriate optical attenuator.

REQUIREMENTS FOR EXTERNAL POWER SUPPLY UNIT (PSU)

- Output voltage 10 V ÷ 20 V DC
- Output current recommended to use PSU with 50% extra power reserve
- Ripple at single and/or double mains frequency < 10 mV p-p
- Ripple & noise < 200 mV p-p
- Output connector type 3.5/1.3 (+) plug
- Short circuit protection
- Double insulated (marked )
- Meet EN 55022 class B conducted emissions requirements, measuring with grounded load
- Recommended PSU - [SYS1121-1220-W2E](#), [SYS1381N-1212-W2E](#)

Technical specifications

Optical input		ORF302*	ORF302T*	ORF302H*
Detection wavelength range		1100 - 1650 nm		
Input level (OLC range)**		-15 ÷ -5 dBm		
RF outputs				
Frequency range	wideband	2 x (290-2350 MHz)		
	DTT	87.5-240 / 470-790 MHz		
SAT IF output level		75 dB μ V		90 dB μ V
DTT output level		75 dB μ V	DTT1 75 dB μ V DTT2 80 dB μ V	85 dB μ V
General				
Return loss / impedance		> 10 dB / 75 Ω		
Supply voltage	DC input	10-20 V		
	wideband outputs	10-20 V		
Power consumption		2.5 W		2.9 W
Operating temperature range		-20 °C ÷ + 50 °C		
Dimensions/Weight (packed)		60x93x23 mm/0.2 kg	72x93x23 mm/0.2 kg	60x93x23 mm/0.2 kg

* Type	Connector IN
ORF302 E	FC/UPC
ORF302H E	FC/UPC
ORF302T E	FC/UPC

** the system performance depends on optical level